

# easy Rack



## EASYPACK

### **E** Armarios 19" para el soporte mural de instalaciones de redes, telecomunicaciones y equipos electrónicos.

Diseñado según normas IEC 60 297-2, DIN 41494 partes 1 y 7, ANSI / EIA-310-D y UNE 20 539-2.

- Premontado en Flat-Pack. Montaje de estructura sin herramientas.
- 2 perfiles 19" de acero, espesor 1.5 mm, desplazables en profundidad.
- Fijación rápida con dos tornillos de 1/4 de vuelta.
- Puerta frontal de vidrio de seguridad, espesor 4 mm, con marco en perfil de aluminio. Sentido de apertura alternable en montaje y cierre por llave.
- Sin puerta posterior, excepto 18U en versión al suelo: en acero 1 mm, sentido apertura alternable en montaje, con cierre por llave.
- Laterales con tapas desmontables (excepto SOHO), con cierres rápidos de 1/4 de vuelta.
- Tapas sup./inf. con premecanizados para fijación de unidad de ventilación de 1 o 2 ventiladores. Incluye tapetas de plástico (sup./inf.) mecanizables para paso de cables.
- Plantilla de montaje a pared incluida (no incluye tornillos de montaje a pared).
- Pies de nivelación en 18U versión a suelo.
- Capacidad de carga recomendada: 40 Kg.

**Acabados:** Pintado epoxy gris grafito texturizado, cantoneras similar a RAL 5007.

**Entrega:** Premontado (Flat-pack) en caja de cartón con asa de plástico (excepto versiones SOHO y FRAME).

### **EN** 19" wall mounted cabinets. For cabling, telecommunications, IT and industrial installations.

Designed in accordance with IEC60 297-2, DIN 41944 part 1 and 7, ANSI/EIA-310 and UNE 20 539-2.

- Delivered flat packed for ease of access to all installations. Also reduces associated logistic costs and offers greater protection during transit.
  - Fast and efficient assembly without tools.
  - 2x 19" mounting profiles. Variable depth, in 20mm increments. Numbered "U's" optional.
  - Fast fixings 1/4 turn locks.
  - New front door with aluminium frame. Tempered, smoked safety glass.
  - No rear panel or door. 18U self-standing version includes rear door with key lock as standard.
  - Easily removable side panels with 2x 1/4 turn locks. Except SOHO version.
  - Newly designed top and base panels, with ventilated areas for installation of the new modular fan trays.
  - New cable entry options for the top panels. With plastic blanking covers or optional brush strip fittings.
  - Template for wall mounting, included.
  - Levelling feet included with the 18U self-standing version.
  - Distributed recommended load capacity: 40 Kg
- Finishes:** Graphite Grey epoxy paint and standard blue corners pieces similar to RAL 5007
- Delivery:** Flat packed with carrying handle. (Except SOHO and FRAME versions).

### **F** Coffrets muraux 19", pour installations de câblage, Télécommunications, IT et installations industrielles. Conception selon les normes IEC 60 297-2, DIN 41944 part. 1 & 7, ANSI/EIA-310 et UNE 20 359-2.

- Livraison en emballage "Flat-pack" pour un accès facilité quelque soit le lieu de l'installation, réduisant de même les besoins et les coûts logistiques, tout en assurant également une meilleure protection lors du transport.
  - Assemblage rapide et efficient sans outillage.
  - 2x Profilés intérieurs 19". Profondeur variable par pas de 20 mm. Numérotation des "U" en option. Fixation rapide par boulons 1/4 de tour.
  - Nouvelle porte avec cadre d'aluminium et verre de sécurité trempé et fumé.
  - Pas de panneau postérieur ou de porte. Seule la version 18U de sol en produit standard inclut une porte postérieure avec serrure.
  - Latéraux facilement démontables par 2 boulons 1/4 de tour, à l'exception de la version SOHO.
  - Nouveaux design de panneaux de toit avec zones d'aération prêtes pour le montage des nouvelles unités de ventilation modulaire.
  - Nouvelles sorties de câblage en toit et base pour l'installation de panneaux passe-câbles à balai ou bien de panneaux pleins mécanisables.
  - Plan fourni pour le montage mural. Pies de nivellement inclus dans la version 18U de sol. Capacité de charge distribuée recommandée: 40 Kg.
- Finitions:** peinture époxy gris graphite, couvercles de cornières standard en bleu similaire à RAL 5007.
- Emballage:** en "Flat pack". Avec poignée de transport (excepté FRAME).



EASYPACK



EASYPACK 18U STAND



EASYPACK SOHO



EASYPACK FRAME



## EASYPACK

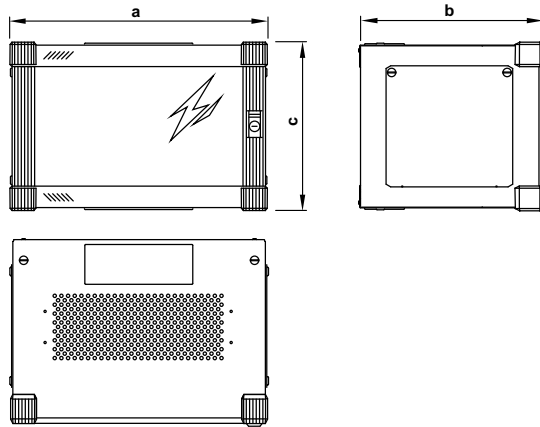

Code	19"	U/HE	a	b	c	Puerta frontal Front door Porte frontale	Puerta posterior Rear door Porte arrière
32250406	*	6	580	421	384	*	
32250409	*	9	580	421	517	*	
32250606	*	6	580	621	384	*	
32250609	*	9	580	621	517	*	
32250512	*	12	580	521	651	*	
32250612	*	12	580	621	651	*	
32250515	*	15	580	521	784	*	
32250615	*	15	580	621	784	*	
32250618	*	18	580	621	917	*	
32252618	*	18	580	621	917	*	*

## EASYPACK SOHO

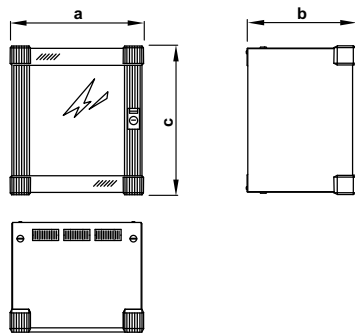

Code	19"	U/HE	a	b	c	Puerta frontal Front door Porte frontale	Puerta posterior Rear door Porte arrière
32251307		7	385	315	428	*	

## EASYPACK FRAME

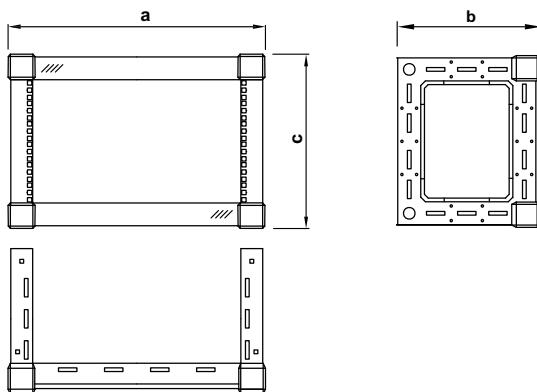

Code	19"	U/HE	a	b	c	Puerta frontal Front door Porte frontale	Puerta posterior Rear door Porte arrière
32250106	*	6	559	316	378		



Embalaje Flat-pack en toda la gama.  
Flat-pack for all the ranges  
Livraison en Flat-pack pour toute la gamme.



**EASYRACK**  
6, 9, 12, 15, 18U

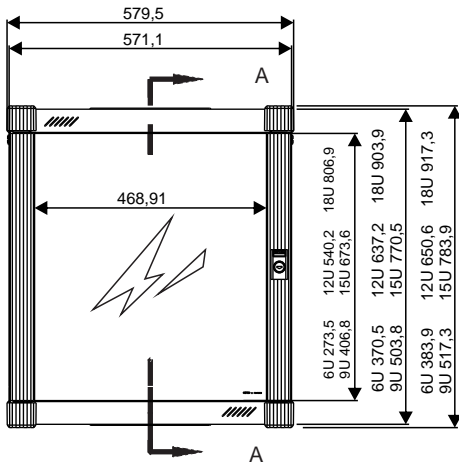
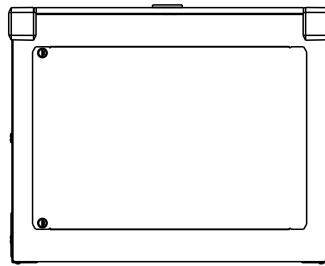
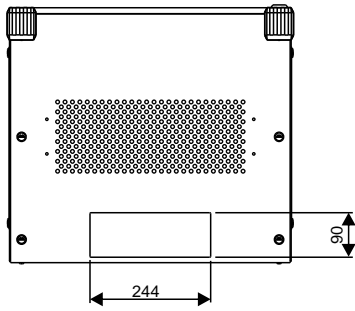

SIN PUERTA / WITHOUT DOOR / SANS PORTE

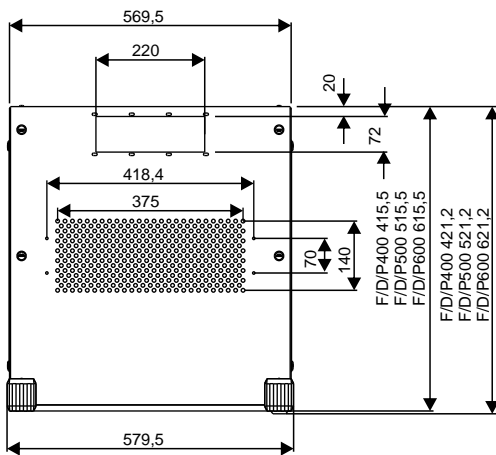
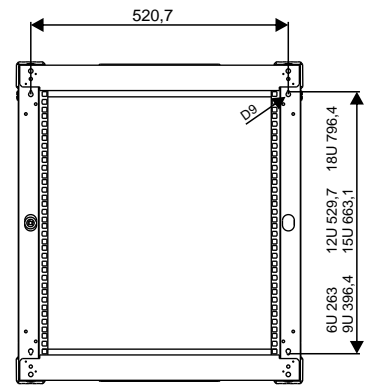
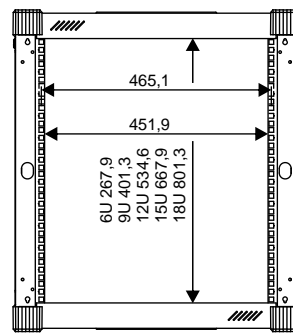

A-A

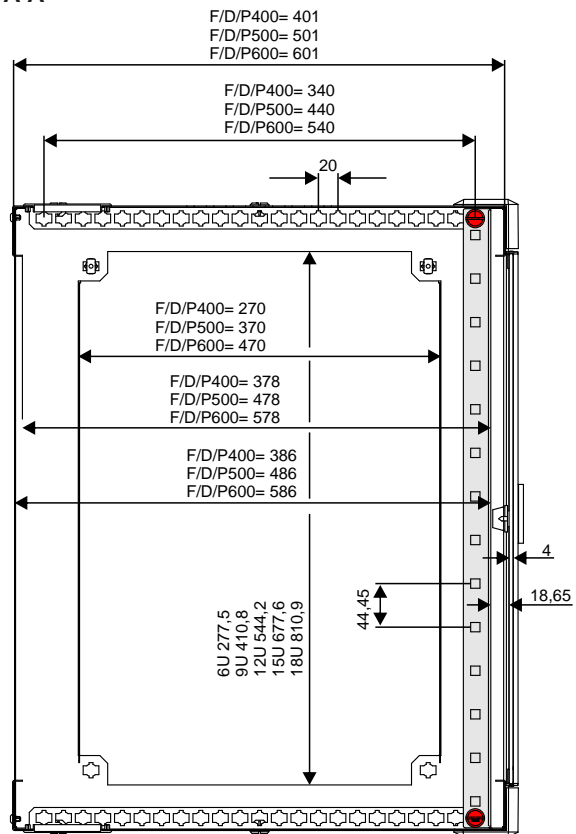

**EASYPACK 18U STAND**  
**( CODE 32252618 )**

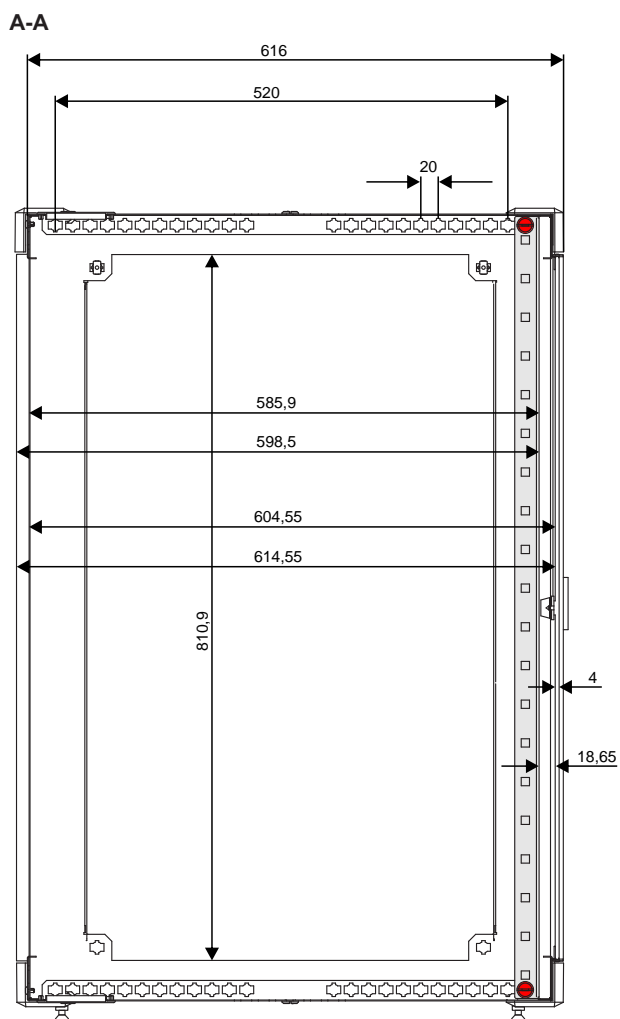
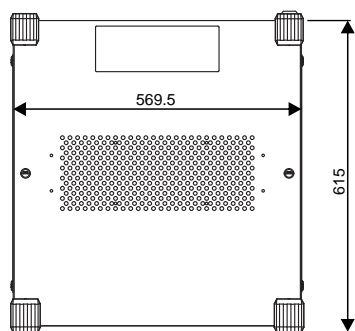
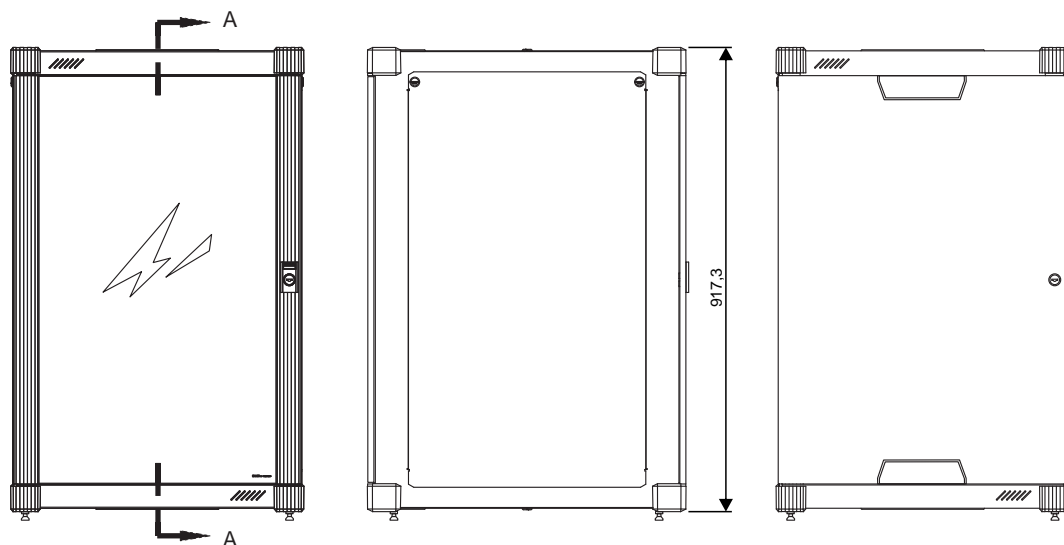

## EASYPACK SOHO

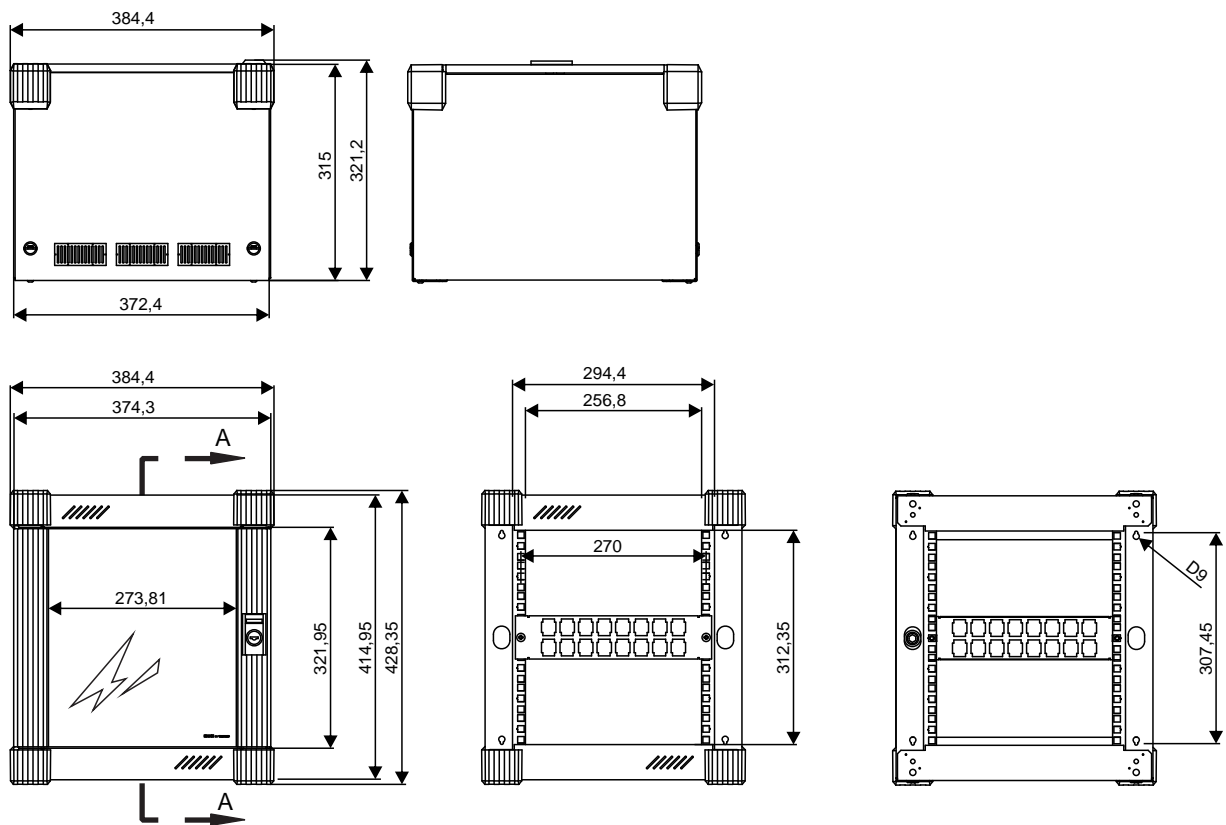

## EASYPACK FRAME

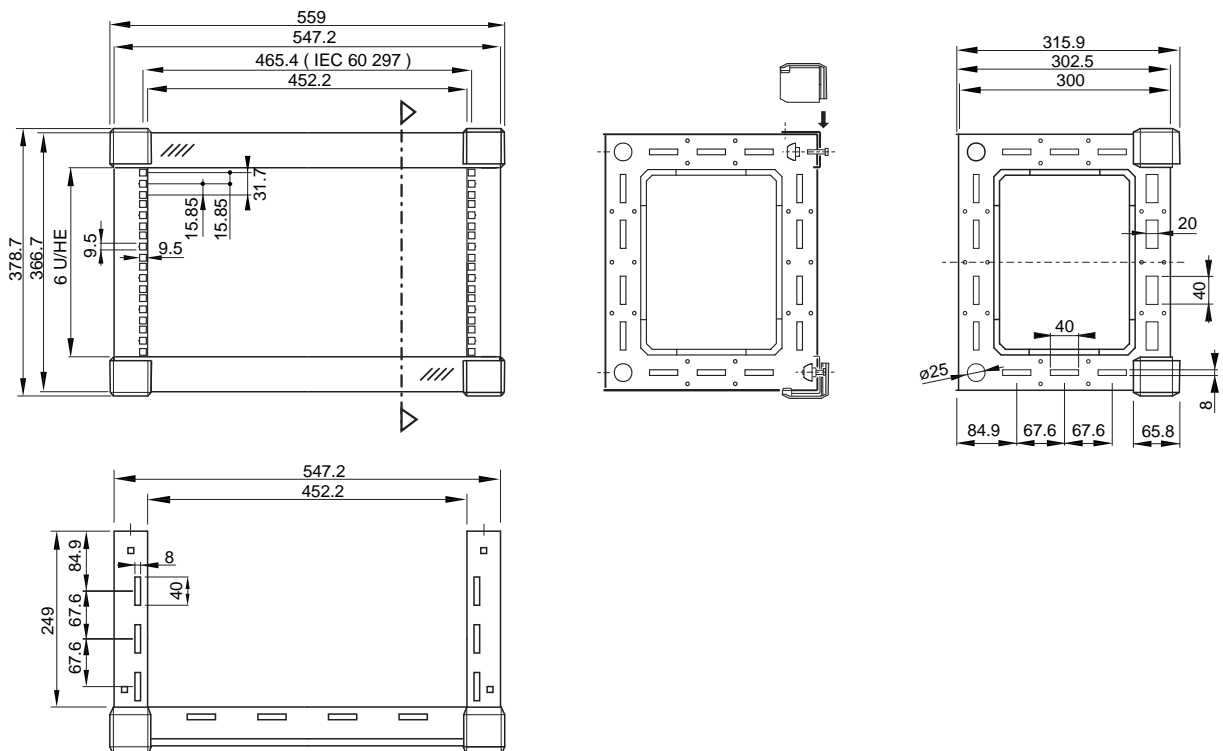

ARGENTINA - AUSTRALIA - BELARUS - BELGIUM - BRAZIL - BULGARIA - CHILE - COLOMBIA - DENMARK - DOMINICAN REPUBLIC - FINLAND - FRANCE - GERMANY - GREECE - HONG KONG - INDIA - ISRAEL - ITALY - JAPAN - LEBANON - MACAO - MALTA - MAURITIUS - MEXICO - MOROCCO - NORWAY - PARAGUAY - PORTUGAL - REUNION - ROMANIA - RUSSIA - SPAIN - SWEDEN - SWITZERLAND - SYRIA - THE NETHERLANDS - TUNISIA - UNITED KINGDOM - UNITED STATES - URUGUAY



#### RETEX

RETEX, S.A.  
Avda. Tecnología, 35  
08840 VILADECANS (Barcelona)  
España  
[www.retex.es](http://www.retex.es)  
email: [retex@retex.es](mailto:retex@retex.es)  
Tel +34 93 264 98 50  
Fax +34 93 659 23 68

#### RETEX Latinoamérica Uruguay

RETEX TELECOMUNICACIONES, S.A.  
Pereira de la Luz, 1080  
11300 MONTEVIDEO  
Uruguay  
[www.retextelecom.com](http://www.retextelecom.com)  
email: [retex@retextelecom.com](mailto:retex@retextelecom.com)  
Tel. +5982 6223408  
Fax +5982 2045797

#### RETEX Asia India

RETEX RACKS & ENCLOSURES PVT LTD.  
D-220 Ansa Industrial Estate Road  
Saki-Vihar Road, Andheri East  
MUMBAI 400072  
India  
[www.retex.co.in](http://www.retex.co.in)  
email: [retex@retex.co.in](mailto:retex@retex.co.in)  
Phone: +9122 28575934



RETEX colabora con la ONG [www.figueralia.org](http://www.figueralia.org)  
*RETEX collaborates with the NGO [www.figueralia.org](http://www.figueralia.org)*  
RETEX collabore avec la ONG [www.figueralia.org](http://www.figueralia.org)

01/2011. Code 77200050.  
RETEX, S.A. se reserva el derecho a introducir modificaciones en la información de este catálogo sin previo aviso. *RETEX, S.A. reserves the right to change the information included in this catalogue without prior notice.* RETEX, S.A. se réserve le droit de procéder a des modifications des informations du présent catalogue sans préavis.